

**Agenda
Item
IV.B.**

State of Oregon

Board memo

Building Codes Division

August 15, 2008

To: Oregon State Plumbing Board

From: Terry Swisher
Chief Plumbing Inspector

Subject: 2006 International Plumbing Code (IPC) – Appendix C – Gray Water Recycling Systems

Action request:

None, informational only.

Background:

Kraig Stevenson, Senior Regional Manager, International Codes Council (ICC) Governmental Relations, wished to provide the plumbing board a copy of the gray water recycling provisions of the IPC. Mr. Stevenson read articles on the board's review of water conservation system standards and wanted to make the board aware of the IPC language.

Discussion:

The appendix addresses subsurface irrigation with gray water, as well as the use of gray water to flush toilets and urinals. Disinfection of the gray water is addressed. The treated gray water is required to be dyed blue or green when supplied to plumbing fixtures. Distribution piping is required to be identified as non-potable water.

APPENDIX C

GRAY WATER RECYCLING SYSTEMS

Note: Section 301.3 of this code requires all plumbing fixtures that receive water or waste to discharge to the sanitary drainage system of the structure. In order to allow for the utilization of a gray water system, Section 301.3 should be revised to read as follows:

301.3 Connections to drainage system. All plumbing fixtures, drains, appurtenances and appliances used to receive or discharge liquid wastes or sewage shall be directly connected to the sanitary drainage system of the building or premises, in accordance with the requirements of this code. This section shall not be construed to prevent indirect waste systems required by Chapter 8.

Exception: Bathtubs, showers, lavatories, clothes washers and laundry trays shall not be required to discharge to the sanitary drainage system where such fixtures discharge to an approved gray water system for flushing of water closets and urinals or for subsurface landscape irrigation.

SECTION C101 GENERAL

C101.1 Scope. The provisions of this appendix shall govern the materials, design, construction and installation of gray water systems for flushing of water closets and urinals and for subsurface landscape irrigation (see Figures 1 and 2).

C101.2 Definition. The following term shall have the meaning shown herein.

GRAY WATER. Waste discharged from lavatories, bathtubs, showers, clothes washers and laundry trays.

C101.3 Permits. Permits shall be required in accordance with Section 106.

C101.4 Installation. In addition to the provisions of Section C101, systems for flushing of water closets and urinals shall comply with Section C102 and systems for subsurface landscape irrigation shall comply with Section C103. Except as provided for in Appendix C, all systems shall comply with the provisions of the *International Plumbing Code*.

C101.5 Materials. Above-ground drain, waste and vent piping for gray water systems shall conform to one of the standards listed in Table 702.1. Gray water underground building drainage and vent pipe shall conform to one of the standards listed in Table 702.2.

C101.6 Tests. Drain, waste and vent piping for gray water systems shall be tested in accordance with Section 312.

C101.7 Inspections. Gray water systems shall be inspected in accordance with Section 107.

C101.8 Potable water connections. Only connections in accordance with Section C102.3 shall be made between a gray water recycling system and a potable water system.

C101.9 Waste water connections. Gray water recycling systems shall receive only the waste discharge of bathtubs, showers, lavatories, clothes washers or laundry trays.

C101.10 Collection reservoir. Gray water shall be collected in an approved reservoir constructed of durable, nonabsorbent and corrosion-resistant materials. The reservoir shall be a closed and gas-tight vessel. Access openings shall be provided to allow inspection and cleaning of the reservoir interior.

C101.11 Filtration. Gray water entering the reservoir shall pass through an approved filter such as a media, sand or diatomaceous earth filter.

C101.11.1 Required valve. A full-open valve shall be installed downstream of the last fixture connection to the gray water discharge pipe before entering the required filter.

C101.12 Overflow. The collection reservoir shall be equipped with an overflow pipe having the same or larger diameter as the influent pipe for the gray water. The overflow pipe shall be indirectly connected to the sanitary drainage system.

C101.13 Drain. A drain shall be located at the lowest point of the collection reservoir and shall be indirectly connected to the sanitary drainage system. The drain shall be the same diameter as the overflow pipe required in Section C101.12.

C101.14 Vent required. The reservoir shall be provided with a vent sized in accordance with Chapter 9 and based on the diameter of the reservoir influent pipe.

SECTION C102 SYSTEMS FOR FLUSHING WATER CLOSETS AND URINALS

C102.1 Collection reservoir. The holding capacity of the reservoir shall be a minimum of twice the volume of water required to meet the daily flushing requirements of the fixtures supplied with gray water, but not less than 50 gallons (189 L). The reservoir shall be sized to limit the retention time of gray water to a maximum of 72 hours.

C102.2 Disinfection. Gray water shall be disinfected by an approved method that employs one or more disinfectants such as chlorine, iodine or ozone.

C102.3 Makeup water. Potable water shall be supplied as a source of makeup water for the gray water system. The potable water supply shall be protected against backflow in accordance with Section 608. There shall be a full-open valve located on the makeup water supply line to the collection reservoir.

C102.4 Coloring. The gray water shall be dyed blue or green with a food grade vegetable dye before such water is supplied to the fixtures.

C102.5 Materials. Distribution piping shall conform to one of the standards listed in Table 605.4.

C102.6 Identification. Distribution piping and reservoirs shall be identified as containing nonpotable water. Piping identification shall be in accordance with Section 608.8.

SECTION C103

SUBSURFACE LANDSCAPE IRRIGATION SYSTEMS

C103.1 Collection reservoir. Reservoirs shall be sized to limit the retention time of gray water to a maximum of 24 hours.

C103.1.1 Identification. The reservoir shall be identified as containing nonpotable water.

C103.2 Valves required. A check valve and a full-open valve located on the discharge side of the check valve shall be installed on the effluent pipe of the collection reservoir.

C103.3 Makeup water. Makeup water shall not be required for subsurface landscape irrigation systems. Where makeup water is provided, the installation shall be in accordance with Section C102.3.

C103.4 Disinfection. Disinfection shall not be required for gray water used for subsurface landscape irrigation systems.

C103.5 Coloring. Gray water used for subsurface landscape irrigation systems shall not be required to be dyed.

C103.6 Estimating gray water discharge. The system shall be sized in accordance with the gallons-per-day-per-occupant number based on the type of fixtures connected to the gray water system. The discharge shall be calculated by the following equation:

$$C = A \times B$$

A = Number of occupants:

Residential—Number of occupants shall be determined by the actual number of occupants, but not less than two occupants for one bedroom and one occupant for each additional bedroom.

Commercial—Number of occupants shall be determined by the *International Building Code*[®].

B = Estimated flow demands for each occupant:

Residential—25 gallons per day (94.6 lpd) per occupant for showers, bathtubs and lavatories and 15 gallons per day (56.7 lpd) per occupant for clothes washers or laundry trays.

Commercial—Based on type of fixture or water use records minus the discharge of fixtures other than those discharging gray water.

C = Estimated gray water discharge based on the total number of occupants.

C103.7 Percolation tests. The permeability of the soil in the proposed absorption system shall be determined by percolation tests or permeability evaluation.

C103.7.1 Percolation tests and procedures. At least three percolation tests in each system area shall be conducted. The holes shall be spaced uniformly in relation to the bottom depth of the proposed absorption system. More percolation tests shall be made where necessary, depending on system design.

C103.7.1.1 Percolation test hole. The test hole shall be dug or bored. The test hole shall have vertical sides and a horizontal dimension of 4 inches to 8 inches (102 mm to 203 mm). The bottom and sides of the hole shall be scratched with a sharp-pointed instrument to expose the natural soil. All loose material shall be removed from the hole and the bottom shall be covered with 2 inches (51 mm) of gravel or coarse sand.

C103.7.1.2 Test procedure, sandy soils. The hole shall be filled with clear water to a minimum of 12 inches (305 mm) above the bottom of the hole for tests in sandy soils. The time for this amount of water to seep away shall be determined, and this procedure shall be repeated if the water from the second filling of the hole seeps away in 10 minutes or less. The test shall proceed as follows: Water shall be added to a point not more than 6 inches (152 mm) above the gravel or coarse sand. Thereupon, from a fixed reference point, water levels shall be measured at 10-minute intervals for a period of 1 hour. Where 6 inches (152 mm) of water seeps away in less than 10 minutes, a shorter interval between measurements shall be used, but in no case shall the water depth exceed 6 inches (152 mm). Where 6 inches (152 mm) of water seeps away in less than 2 minutes, the test shall be stopped and a rate of less than 3 minutes per inch (7.2 s/mm) shall be reported. The final water level drop shall be used to calculate the percolation rate. Soils not meeting the above requirements shall be tested in accordance with Section C103.7.1.3.

C103.7.1.3 Test procedure, other soils. The hole shall be filled with clear water, and a minimum water depth of 12 inches (305 mm) shall be maintained above the bottom of the hole for a 4-hour period by refilling whenever necessary or by use of an automatic siphon. Water remaining in the hole after 4 hours shall not be removed. Thereafter, the soil shall be allowed to swell not less than 16 hours or more than 30 hours. Immediately after the soil swelling period, the measurements for determining the percolation rate shall be made as follows: Any soil sloughed into the hole shall be removed and the water level shall be adjusted to 6 inches (152 mm) above the gravel or coarse sand. Thereupon, from a fixed reference point, the water level shall be measured at 30-minute intervals for a period of 4 hours, unless two successive water level drops do not vary by more than 0.62 inch (1.59 mm). At least three water level drops shall be observed and recorded. The hole shall be filled with clear water to a point not more than 6 inches (152 mm) above the gravel or coarse sand whenever it becomes nearly empty. Adjustments of the water level shall not be made during the three measurement periods except to the limits of the last measured water level drop. When the first 6 inches (152 mm) of water seeps away in less than 30 minutes, the time interval between measurements shall be 10 minutes and the test run for 1 hour. The water depth shall not exceed 5 inches (127 mm) at any time during the measurement period. The drop that occurs during the final measurement period shall be used in calculating the percolation rate.

C103.7.1.4 Mechanical test equipment. Mechanical percolation test equipment shall be of an approved type.

C103.7.2 Permeability evaluation. Soil shall be evaluated for estimated percolation based on structure and texture in accordance with accepted soil evaluation practices. Borings shall be made in accordance with Section C103.7.1 for evaluating the soil.

C103.8 Subsurface landscape irrigation site location. The surface grade of all soil absorption systems shall be located at a point lower than the surface grade of any water well or reservoir on the same or adjoining property. Where this is not possible, the site shall be located so surface water drainage from the site is not directed toward a well or reservoir. The soil absorption system shall be located with a minimum horizontal distance between various elements as indicated in Table C103.8. Private sewage disposal systems in compacted areas, such as parking lots and driveways, are prohibited. Surface water shall be diverted away from any soil absorption site on the same or neighboring lots.

**TABLE C103.8
LOCATION OF GRAY WATER SYSTEM**

ELEMENT	MINIMUM HORIZONTAL DISTANCE	
	HOLDING TANK (feet)	IRRIGATION DISPOSAL FIELD (feet)
Buildings	5	2
Property line adjoining private property	5	5
Water wells	50	100
Streams and lakes	50	50
Seepage pits	5	5
Septic tanks	0	5
Water service	5	5
Public water main	10	10

For SI: 1 foot = 304.8 mm.

C103.9 Installation. Absorption systems shall be installed in accordance with Sections C103.9.1 through C103.9.5 to provide landscape irrigation without surfacing of gray water.

C103.9.1 Absorption area. The total absorption area required shall be computed from the estimated daily gray water discharge and the design-loading rate based on the percolation rate for the site. The required absorption area equals the estimated gray water discharge divided by the design-loading rate from Table C103.9.1.

**TABLE C 103.9.1
DESIGN LOADING RATE**

PERCOLATION RATE (minutes per inch)	DESIGN LOADING FACTOR (gallons per square foot per day)
0 to less than 10	1.2
10 to less than 30	0.8
30 to less than 45	0.72
45 to 60	0.4

For SI: 1 minute per inch = min/25.4 mm,
1 gallon per square foot = 40.7 L/m².

C103.9.2 Seepage trench excavations. Seepage trench excavations shall be a minimum of 1 foot (304 mm) to a maximum of 5 feet (1524 mm) wide. Trench excavations shall be spaced a minimum of 2 feet (610 mm) apart. The soil absorption area of a seepage trench shall be computed by using the bottom of the trench area (width) multiplied by the length of pipe. Individual seepage trenches shall be a maximum of 100 feet (30 480 mm) in developed length.

C103.9.3 Seepage bed excavations. Seepage bed excavations shall be a minimum of 5 feet (1524 mm) wide and have more than one distribution pipe. The absorption area of a seepage bed shall be computed by using the bottom of the trench area. Distribution piping in a seepage bed shall be uniformly spaced a maximum of 5 feet (1524 mm) and a minimum of 3 feet (914 mm) apart, and a maximum of 3 feet (914 mm) and a minimum of 1 foot (305 mm) from the side-wall or headwall.

C103.9.4 Excavation and construction. The bottom of a trench or bed excavation shall be level. Seepage trenches or beds shall not be excavated where the soil is so wet that such material rolled between the hands forms a soil wire. All smeared or compacted soil surfaces in the sidewalls or bottom of seepage trench or bed excavations shall be scarified to the depth of smearing or compaction and the loose material removed. Where rain falls on an open excavation, the soil shall be left until sufficiently dry so a soil wire will not form when soil from the excavation bottom is rolled between the hands. The bottom area shall then be scarified and loose material removed.

C103.9.5 Aggregate and backfill. A minimum of 6 inches of aggregate ranging in size from ½ to 2½ inches (12.7 mm to 64 mm) shall be laid into the trench below the distribution piping elevation. The aggregate shall be evenly distributed a minimum of 2 inches (51 mm) over the top of the distribution pipe. The aggregate shall be covered with approved synthetic materials or 9 inches (229 mm) of uncompacted marsh hay or straw. Building paper shall not be used to cover the aggregate. A minimum of 9 inches (229 mm) of soil backfill shall be provided above the covering.

C103.10 Distribution piping. Distribution piping shall be not less than 3 inches (76 mm) in diameter. Materials shall comply with Table C103.10. The top of the distribution pipe shall be not less than 8 inches (203 mm) below the original surface. The slope of the distribution pipes shall be a minimum of 2 inches (51 mm) and a maximum of 4 inches (102 mm) per 100 feet (30 480 mm).

**TABLE C103.10
DISTRIBUTION PIPE**

MATERIAL	STANDARD
Polyethylene (PE) plastic pipe	ASTM F 405
Polyvinyl chloride (PVC) plastic pipe	ASTM D 2729
Polyvinyl chloride (PVC) plastic pipe with pipe stiffness of PS 35 and PS 50	ASTM F 1488

C103.11 Joints. Joints in distribution pipe shall be made in accordance with Section 705 of this code.

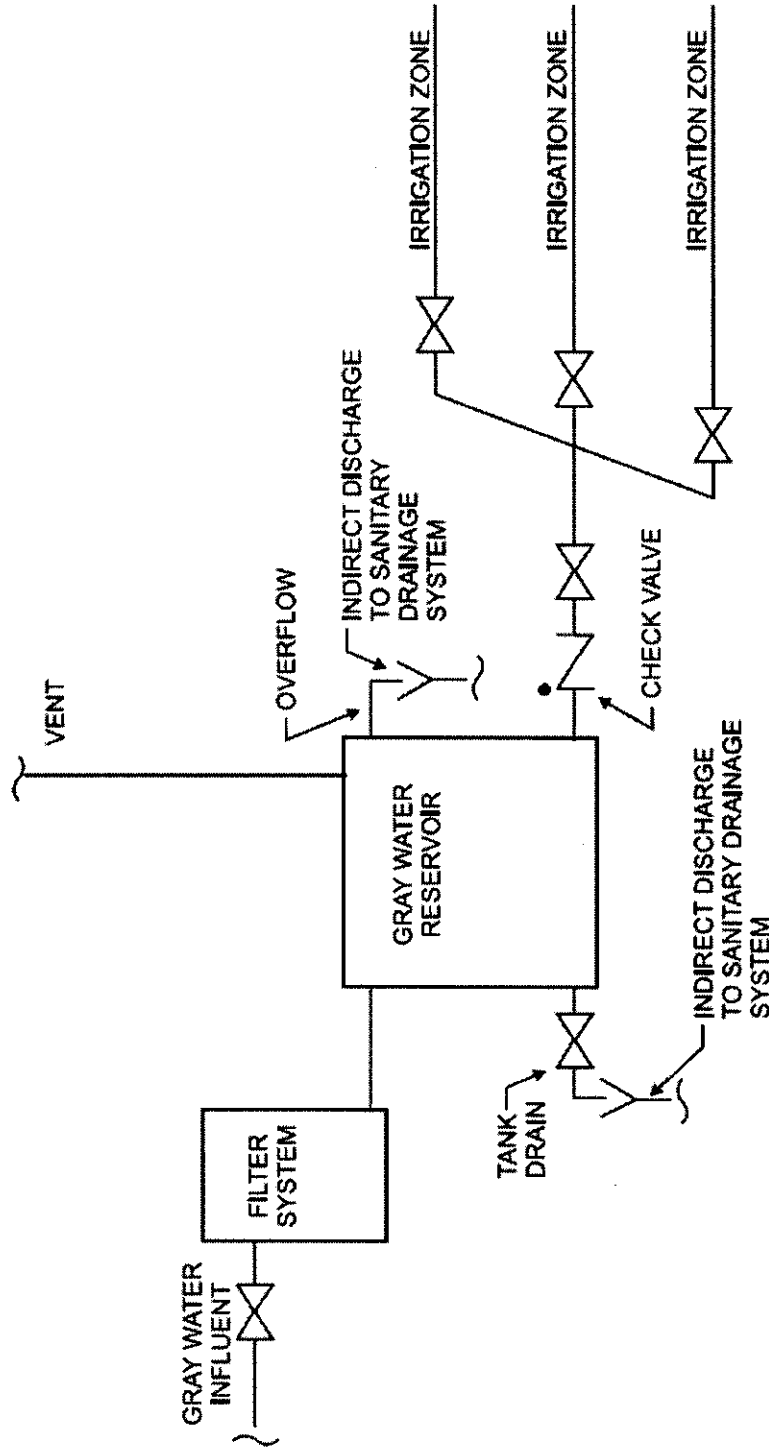

FIGURE 1
GRAY WATER RECYCLING SYSTEM FOR SUBSURFACE LANDSCAPE IRRIGATION

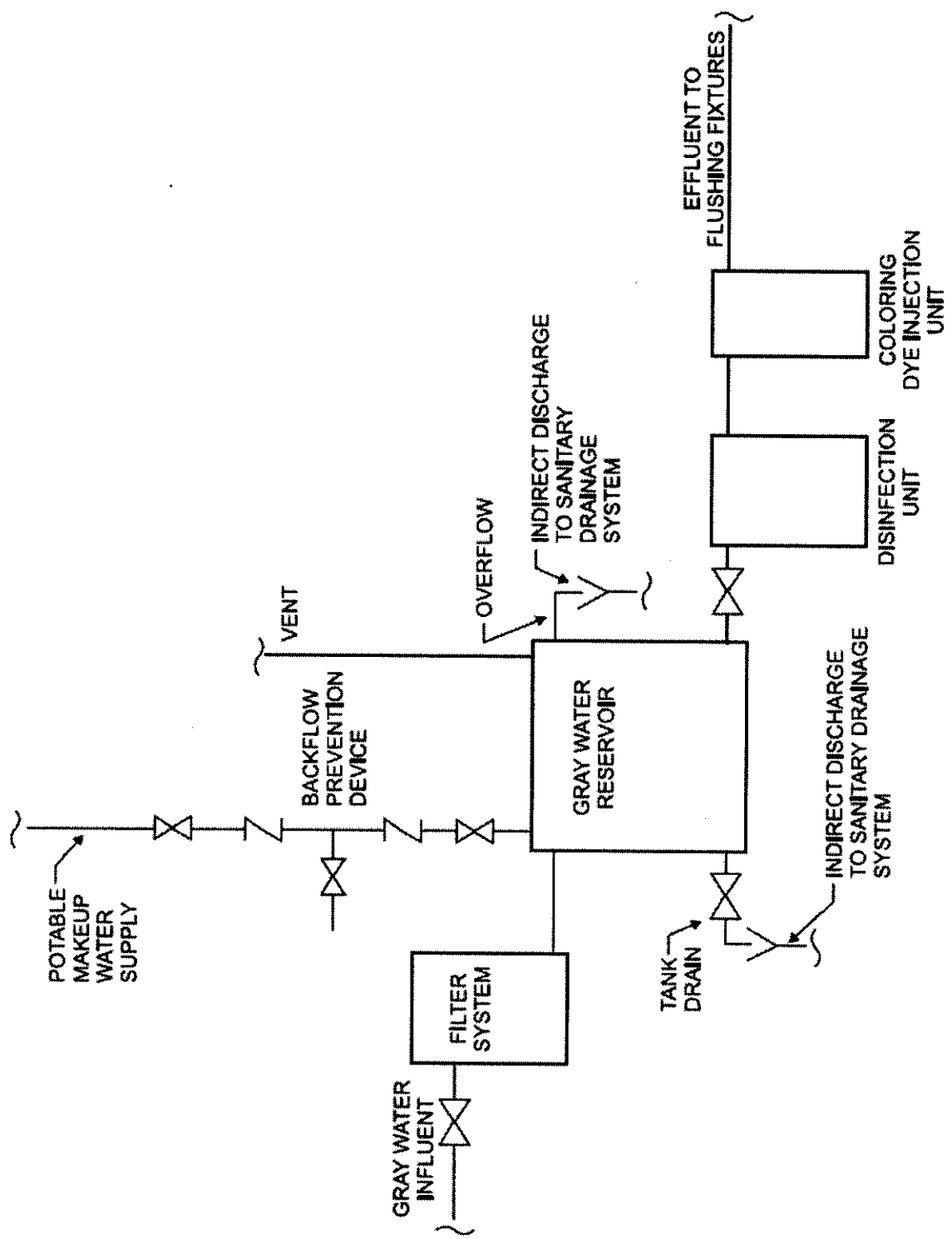

FIGURE 2
GRAY WATER RECYCLING SYSTEM FOR FLUSHING WATER CLOSETS AND URINALS