

**Agenda
Item
VII.C.**

State of Oregon

Board memo

Building Codes Division

August 15, 2008

To: Oregon State Plumbing Board

From: Terry Swisher
Chief Plumbing Inspector

Subject: Siphonic Roof Drain Standard ASTM A112.6.9-2006

Action request:

Approve new product standard for siphonic roof drains ASTM A112.6.9-2006.

Background:

Under ORS 447.152 the board approves minimum safety standards for plumbing products sold in Oregon. The division received a request from Bret Weymouth, specification manager, Braley-Gray & Associates, Inc., for the board to review and consider siphonic roof drainage as an approved engineered system designed by a licensed professional engineer in the State of Oregon.

Discussion:

Mr. Weymouth sent the attached copy of the ASTM A112.6.9 product standard and the ASPE 45 installation standard for consideration. Siphonic roof drainage systems are not addressed in the plumbing code. These are engineered systems, which must be individually designed for each installation. Each drain manufacturer provides computer software to design systems utilizing their products. Each installation of siphonic roof drainage would require site-specific approval by the local building official.

Recommendation:

Approve the ASTM A112.6.9-2006 standard.

IAPMO RESEARCH AND TESTING, INC.

5001 East Philadelphia Street, Ontario, California 91761-2816 • (909) 472-4100 Fax (909) 472-4244 • www.iapmo.org

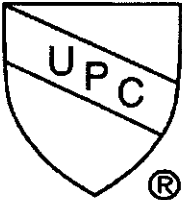

LISTED PRODUCTS

IAPMO Research and Testing, Inc. is a product certification body which tests and inspects samples taken from the supplier's stock or from the market or a combination of both to verify compliance to the requirements of applicable codes and standards. This activity is coupled with periodic surveillance of the supplier's factory and warehouses as well as the assessment of the supplier's Quality Assurance System. This listing is subject to the conditions set forth in the characteristics below and is not to be construed as any recommendation, assurance or guarantee by IAPMO Research and Testing, Inc. of the product acceptance by Authorities Having Jurisdiction.

Effective Date: November 2007 Void After: November 2008
Product: Siphonic Roof Drains File No. 5138
Issued To: Jay R. Smith Mfg. Co.
2781 Gunter Park Drive East
Montgomery, AL 36109

IDENTIFICATION: Each siphonic roof drain shall be permanently marked at the dome, bodies, and baffle plates with the manufacturers name or trademark. The baffle plate and drain body shall also be marked with the baffle plate model number, resistance value, K, and the words, "REPLACE MISSING BAFFLE WITH MODEL___." The marking shall be located at a location visible after installation. The product shall also bear the UPC® certification mark.

CHARACTERISTICS: The roof drains in this listing are designed, manufactured, and installed in piping systems that are intended to operate under depressurized siphonic conditions created by the connected piping system. To be installed in accordance with the manufacturer's instructions and the requirements of the latest edition of the Uniform Plumbing Code.

Products listed on this certificate have been tested by an IAPMO R&T recognized laboratory. This recognition has been granted based upon the laboratory's compliance to the applicable requirements of ISO/IEC 17025.

Chairman, Product Certification Committee

Executive Director

This listing is for the period indicated herein and is void after the date shown above. Any change in material, manufacturing process, marking or design without having first obtained the approval of the Product Certification Committee, or any evidence of non-compliance with applicable codes and standards or of inferior workmanship, may be deemed sufficient cause for revocation of this listing. Reproduction of or reference to this form for advertising purposes may be made only by specific written permission of IAPMO Research and Testing, Inc. Any alteration of this certificate could be grounds for revocation of the listing.

IAPMO RESEARCH AND TESTING, INC. LISTED PRODUCTS

Page 2

Effective Date: November 2007

Void After: November 2008

Product: Siphonic Roof Drains

File No. 5138

Issued To: Jay R. Smith Mfg. Co.

MODELS:

1005 Siphonic Roof Drain - 2", 2-1/2", 3", and 4"
1605 Siphonic Gutter Drain - 2"

Sponsor of the Uniform Plumbing Code[®], Uniform Mechanical Code[®],
Uniform Swimming Pool, Spa and Hot Tub Code[®],
and Uniform Solar Energy Code[®]

DOC#081A

ASME A112.6.9-2005

Siphonic Roof Drains

AN AMERICAN NATIONAL STANDARD



The American Society of
Mechanical Engineers

ASME A112.6.9-2005

Siphonic Roof Drains

AN AMERICAN NATIONAL STANDARD



The American Society of
Mechanical Engineers

Three Park Avenue • New York, NY 10016

Date of Issuance: September 30, 2005

The next edition of this Standard is scheduled for publication in 2010. There will be no addenda issued to this edition.

ASME issues written replies to inquiries concerning interpretations of technical aspects of this Standard. The interpretations are not part of the Standard.

ASME is the registered trademark of The American Society of Mechanical Engineers.

This code or standard was developed under procedures accredited as meeting the criteria for American National Standards. The Standards Committee that approved the code or standard was balanced to assure that individuals from competent and concerned interests have had an opportunity to participate. The proposed code or standard was made available for public review and comment that provides an opportunity for additional public input from industry, academia, regulatory agencies, and the public-at-large.

ASME does not "approve," "rate," or "endorse" any item, construction, proprietary device, or activity.

ASME does not take any position with respect to the validity of any patent rights asserted in connection with any items mentioned in this document, and does not undertake to insure anyone utilizing a standard against liability for infringement of any applicable letters patent, nor assume any such liability. Users of a code or standard are expressly advised that determination of the validity of any such patent rights, and the risk of infringement of such rights, is entirely their own responsibility.

Participation by federal agency representative(s) or person(s) affiliated with industry is not to be interpreted as government or industry endorsement of this code or standard.

ASME accepts responsibility for only those interpretations of this document issued in accordance with the established ASME procedures and policies, which precludes the issuance of interpretations by individuals.

No part of this document may be reproduced in any form,
in an electronic retrieval system or otherwise,
without the prior written permission of the publisher.

The American Society of Mechanical Engineers
Three Park Avenue, New York, NY 10016-5990

Copyright © 2005 by
THE AMERICAN SOCIETY OF MECHANICAL ENGINEERS
All rights reserved
Printed in U.S.A.

CONTENTS

Foreword	iv
Committee Roster	v
Correspondence With the A112 Committee	vi
1 General	1
2 Acceptable Materials and Components	1
3 Testing	2
4 Accessories	5
5 Markings	5
Figures	
1 Resistance Value Apparatus	3
2 Depth Versus Flow Apparatus	5

FOREWORD

The American Society of Mechanical Engineers has prepared this Standard for the purpose of establishing standardization and uniformity in the manufacture and testing of siphonic roof drains as well as the practice of siphonic roof drainage design in the United States. This Standard is not intended to be static or immutable but shall be subject to periodic review and revision.

Suggestions for the improvement of this Standard will be welcome. They should be sent to The American Society of Mechanical Engineers, Attn: Secretary, A112 Standards Committee, Three Park Avenue, New York, NY 10016-5990.

This Standard was approved as an American National Standard on July 8, 2005.

ASME A112 COMMITTEE

Standardization of Plumbing Materials and Equipment

(The following is the roster of the Committee at the time of approval of this Standard.)

OFFICERS

D. W. Viola, Chair
S. A. Remedios, Vice Chair
C. J. Gomez, Secretary

COMMITTEE PERSONNEL

R. H. Actroyd, Rand Engineering
J. A. Ballanco, JB Engineering and Code Consulting
J. Bowser, Sanitary for All Ltd.
M. N. Burgess, Burgess Group, Inc.
S. L. Cavanaugh, Consultant
A. Ciechanowski, NSF International
A. Cohen, Arthur Cohen and Associates
P. V. DeMarco, American Standard, Inc.
N. Covino, Alternate, American Standard, Inc.
G. S. Duren, Code Compliance, Inc.
R. Emmerson, Consultant
L. S. Galowin, Consultant
C. J. Gomez, The American Society of Mechanical Engineers
R. I. Greenwald, Sunroc Corp.
E. Ho, IAPMO

D. E. Holloway, SGS U.S. Testing Co.
M. Klimboff, Consultant
M. T. Kobel, IAPMO
N. M. Kummerlen, Moen, Inc.
L. A. Mercer, Alternate, Moen, Inc.
J. W. Lauer, Sloan Valve Co.
R. M. Martin, California Energy Commission
P. W. Meikle, Consultant
S. Rawalpindiwala, Kohler Co.
J. A. Sargent, Alternate, Kohler Co.
S. A. Remedios, Delta Faucet Co.
G. L. Simmons, Charlotte Pipe and Foundry
L. M. Simcik, ICC International
W. M. Smith, Jay R. Smith Mfg. Co.
D. W. Viola, Plumbing Manufacturers Institute
R. E. White, Consultant
W. C. Whitehead, Plumbing and Drainage Institute

PROJECT TEAM 6.9 – SIPHONIC ROOF DRAINS

J. M. Rattenbury, Project Team Leader, RMS Engineering LLC
P. Sommerhein, Deputy Project Team Leader, Sommerhein, AB
W. M. Smith, Project Team Secretary, Jay R. Smith Mfg. Co.
S. Arthur, Heriot-Watt University
G. S. Duren, Code Compliance, Inc.

S. J. McDanal, Jay R. Smith Mfg. Co.
J. S. Moore, Jr., CHB – A Joint Venture
J. D. Sargeant, Cast Iron Soil Pipe Institute
M. Wearing, CRM Rainwater Drainage Consultancy Ltd.
K. L. Yap, Fast Flow Siphonic PTE Ltd.

CORRESPONDENCE WITH THE A112 COMMITTEE

General. ASME Standards are developed and maintained with the intent to represent the consensus of concerned interests. As such, users of this Standard may interact with the Committee by requesting interpretations, proposing revisions, and attending Committee meetings. Correspondence should be addressed to:

Secretary, A112 Standards Committee
The American Society of Mechanical Engineers
Three Park Avenue
New York, NY 10016-5990

Proposing Revisions. Revisions are made periodically to the Standard to incorporate changes that appear necessary or desirable, as demonstrated by the experience gained from the application of the Standard. Approved revisions will be published periodically.

The Committee welcomes proposals for revisions to this Standard. Such proposals should be as specific as possible, citing the edition, the paragraph number(s), the proposed wording, and a detailed description of the reasons for the proposal, including any pertinent documentation. When appropriate, proposals should be submitted using the A112 Project Initiation Request Form.

Interpretations. Upon request, the A112 Committee will render an interpretation of any requirement of the Standard. Interpretations can only be rendered in response to a written request sent to the Secretary of the A112 Standards Committee.

The request for interpretation should be clear and unambiguous. It is further recommended that the inquirer submit his/her request in the following format:

Subject: Cite the applicable paragraph number(s) and the topic of the inquiry.
Edition: Cite the applicable edition of the Standard for which the interpretation is being requested.
Question: Phrase the question as a request for an interpretation of a specific requirement suitable for general understanding and use, not as a request for an approval of a proprietary design or situation. The inquirer may also include any plans or drawings that are necessary to explain the question; however, they should not contain proprietary names or information.

Requests that are not in this format will be rewritten by the Committee prior to being answered, which may inadvertently change the intent of the original request.

ASME procedures provide for reconsideration of any interpretation when or if additional information that might affect an interpretation is available. Further, persons aggrieved by an interpretation may appeal to the cognizant ASME Committee or Subcommittee. ASME does not "approve," "certify," "rate," or "endorse" any item, construction, proprietary device, or activity.

Attending Committee Meetings. The A112 Standards Committee schedules meetings as needed, which are open to the public. Persons wishing to attend any meeting should contact the Secretary of the A112 Standards Committee.

SIPHONIC ROOF DRAINS

1 GENERAL

1.1 Scope

This Standard establishes minimum requirements and provides guidelines for the proper design, installation, examination, and testing of siphonic roof drains. It includes definitions of terms and parameters involved in the proper design of siphonic drainage systems.

This Standard applies to roof drains designed, manufactured, and installed in piping systems that are intended to operate under depressurized siphonic conditions created by the connected piping system.

Unless noted otherwise in this Standard, the requirements and standards for roof drains specified in ASME A112.6.4 do not apply to siphonic roof drains.

This Standard does not apply to conventional roof drains covered under ASME A112.6.4.

It is not the intent of this Standard to specify that a drain of a given diameter must drain a minimum or maximum amount of water. It is the intent of this Standard to provide standardized test procedures to ensure that drain products are evaluated equally.

This Standard does not dictate minimum flow or depth performance criteria for siphonic roof drains. Instead, it specifies standard test procedures to be performed on siphonic roof drain products to document their actual performance and physical limits. These data are to be made available in manufacturer literature for use by designers for selecting the drain product and entering performance characteristics into design calculations.

1.2 Units of Measurement

Values are stated in U.S. Customary units and in the International System of Units (SI). The U.S. Customary units shall be considered as the standard.

1.3 Reference

The following document forms a part of this Standard to the extent specified herein. Unless otherwise indicated, the latest edition shall apply.

ASME A112.6.4, Roof, Deck, and Balcony Drains

Publisher: The American Society of Mechanical Engineers (ASME), Three Park Avenue, New York, NY 10016-5990; Order Department: 22 Law Drive, P.O. Box 2300, Fairfield, NJ 07007-2300

1.6 Definitions and Nomenclature

1.6.1 Definitions

air baffle: a device that limits the flow of air into a drain, causing the connected drainage piping to run at full-bore flow at dimensional rainfall intensity with a limited water depth on the roof surface.

depressurized: the condition or state of being below atmospheric or ambient pressure.

designer: the specifier of a siphonic roof drain product.

drain outlet: the drain "neck" of a siphonic roof drain configured to connect to the tailpiece with a standard coupling device.

full-bore flow: the flow of water in a pipe where theoretically 100% of the cross-section of the pipe bore is filled. In practical terms, full-bore flow is regarded as achieved at water content greater than 95% by volume.

single resistance value, K_i : a coefficient that is characteristic of a pipe fitting's or drain's contribution to energy losses.

1.6.2 Nomenclature

cfs = cubic feet per second

d_i = pipe inner diameter, ft

f = friction factor (dimensionless)

g = gravitational constant, 32.2 ft/sec²

gpm = gallons per minute

h_i = height, ft

K_i = single resistance value (dimensionless)

k_0 = resistance coefficient (dimensionless)

L = pipe length, ft

L/s = liters (metric liquid) per second

P = static pressure, lb_f/ft² or ft H₂O

Q = volumetric flow, cfs

Re = Reynold's Number (dimensionless)

ρ = fluid density, slug/ft³

V = fluid velocity, ft/sec

ν = fluid kinematic viscosity, ft²/sec

w.c. = water column

2 ACCEPTABLE MATERIALS AND COMPONENTS

2.1 Siphonic Roof Drains

The materials of construction, finishes, and hardware components used to manufacture siphonic roof drains shall comply with the requirements of ASME A112.6.4, para. 5.

3 TESTING

3.1 General

3.1.1 Manufacturers of siphonic roof drains may utilize existing conventional drain body designs with an air baffle adaptor to achieve siphonic capability when connected to a properly engineered siphonic drainage piping system. This adaptation, however, requires hydraulic analysis in order to ensure the baffle design is stable, will be capable of priming, and will minimize the depth of water on the roof as much as possible.

3.1.2 Siphonic roof drain products shall be verified experimentally and have documented results.

3.1.3 The design of any air baffle and drain shall follow three main principles:

(a) It shall be able to prime the test standpipe quickly. Thus, the height of the baffle above the sump bowl should be minimized. This will help achieve a high Reynolds Number beneath the baffle and the necessary turbulence for proper air to water mixing during priming.

(b) The baffle shall not introduce a limiting effect with respect to maximum flow. In other words, the drain shall be limited in maximum flow capacity by the fixed spigot drain diameter and not by the introduction of a baffle.

(c) The first two goals must be balanced with the desire to have a minimum of water depth on the roof above the baffle, which means that the resistance of the baffle/drain/strainer combination should be minimized.

3.2 Design of Siphonic Drains

3.2.1 The design of any siphonic roof drain shall follow the basic principles described in para. 3.1.3.

3.2.2 The materials, spigot connections, components, and leaf guard designs of siphonic roof drains shall meet with the minimum requirements of ASME A112.6.4, with the exception of the air baffle design.

3.2.3 This Standard is not intended to restrict or prohibit the development or application of new and innovative siphonic roof drainage products provided that such products conform to the spigot connection requirements of ASME A112.6.4.

3.2.3.1 A spigot connection type shall not reduce or increase the flow path in a manner that will alter the drain's tested single resistance value.

3.3 Testing of Siphonic Roof Drains

3.3.1 The following test procedures shall be applied to siphonic roof drain products.

3.3.2 These tests have three purposes

(a) to determine the relationship between the flow rate entering the drain and the depth of water at the

approach to the drain (i.e., the flow rating curve for the product)

(b) to determine the head loss coefficient (i.e., single resistance value) for the drain for use by the designer for designing the piping system in which the drain will be installed

(c) to check the effectiveness of the drain at preventing entry of air and for the speed of response to sudden changes in flow rate

3.3.3 The performance characteristics of a siphonic roof drain product are vital in the attainment of full-bore flow in the connected piping system.

3.3.4 The relationship between flow rate and upstream depth of rain water depends on where the drain is to be installed. For a given flow rate, the depth will be less on a flat roof than in a gutter. The narrower the gutter, the greater the upstream depth. Siphonic roof drains shall be tested for the most critical condition in which the drain is intended to be installed.

3.3.5 These test procedures do not include the performance and flow capacity of the connected siphonic piping system.

3.4 Test Apparatus, Single Resistance Value (Loss Coefficient)

3.4.1 The test apparatus (Fig. 1) for quantifying a siphonic roof drain single resistance value shall consist of a minimum 39.4 in. (1 m) radius test tank (A) of sufficient height or freeboard [12 in. (305 mm) minimum] with an open top and a level test section (B) not less than a 35.4 in. (0.9 m) radius. The level floor section shall not deviate more than $\pm \frac{3}{32}$ in. (± 4 mm) from the horizontal. The tank (A) shall have a maximum overall surface area of 53.8 ft² (5 m²).

3.4.2 The test tank (A) shall be supplied with water at four points (C) equally spaced near the tank center.

3.4.3 Water shall be pumped from a suitable reservoir using a pump or array of pumps capable of providing a range of flow from the minimum test flow condition to the maximum anticipated flow for the product(s) being tested. Maximum flows of up to 2,000 gpm (126 L/s) or more may be required.

3.4.4 Flow rate shall be measured by a suitable flow element in the supply pump discharge with a turndown ratio of 100:1. Flow shall be measured to an accuracy of $\pm 1\%$. Calibrate the flow output to read in units of cubic feet per second (cfs).

3.4.5 Water depths in the level test section (B) shall be measured to an accuracy of ± 0.04 in. (± 1 mm) at a location 20 in. ± 1 in. (500 mm ± 25 mm) from the center of the drain product. For gutter flow simulations, water depth shall be measured along the centerline of the simulated gutter.

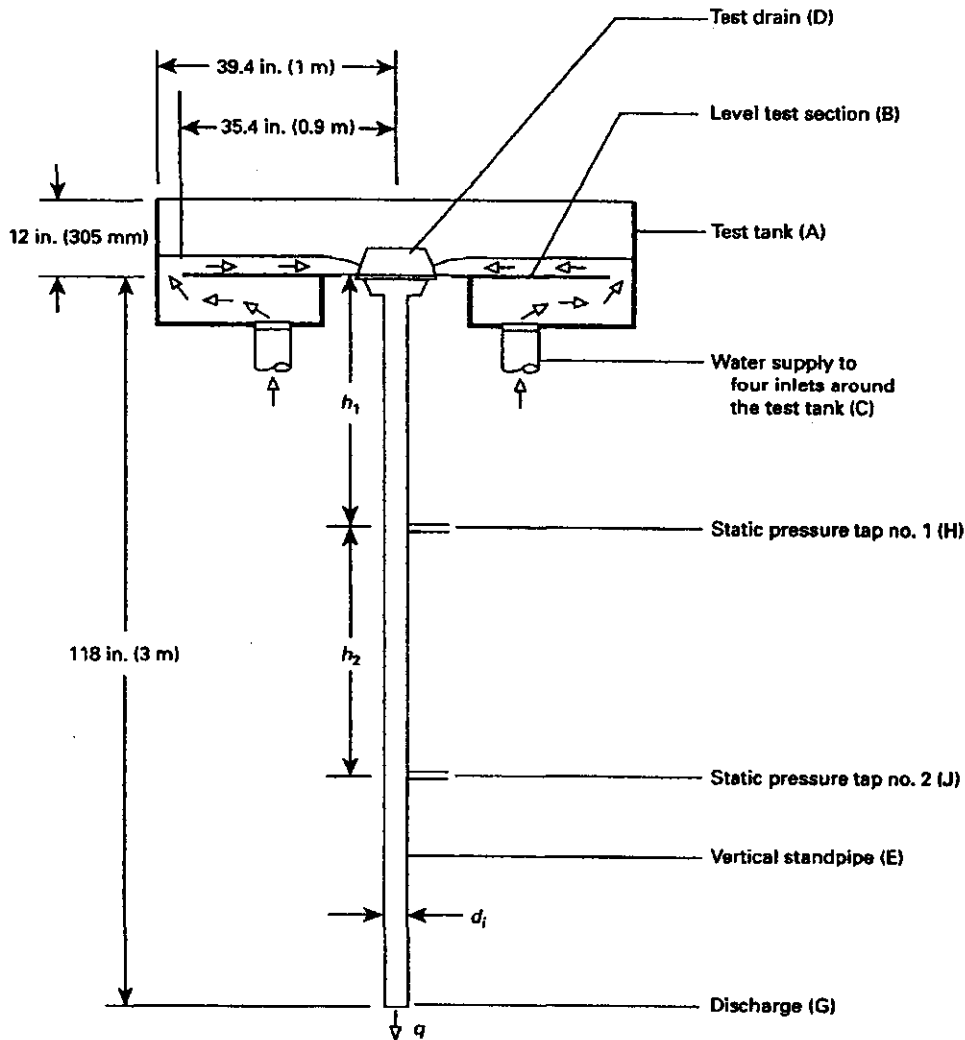

Fig. 1 Resistance Value Apparatus

3.4.6 The center of the level test section (B) shall be capable of accepting the roof drain product to be tested (D), normally by fastening the drain's flashing clamp and body to a fixed circular opening or sump receiver installed in accordance with the manufacturer's installation instructions.

3.4.7 The single resistance value, K , of the drain shall be obtained by connection of a vertical standpipe (E), not less than 118 in. \pm 4 in. (3 m \pm 100 mm) long, with a diameter differing from that of the drain outlet by not more than \pm 0.08 in. (\pm 2 mm). The standpipe shall discharge (G) to a suitable water reservoir for recirculation.

3.4.8 Two static pressure taps [(H) and (J)] shall be installed, a minimum of ten pipe diameters from the drain outlet and ten pipe diameters apart. There shall be no pipe joints or couplings between the pressure taps. Pressure taps shall not be located within 20 in. (0.5 m) of the discharge (G). Pressure shall be measured at full-bore conditions using calibrated pressure transducers, capable of reading to an accuracy of \pm 0.1 in. w.c. (\pm 2.5 mm w.c.).

3.4.9 The test shall be performed by filling the vessel by means of a pump or array of pumps, flow meter, and regulating valve. Slowly increase flow rate until the drain reaches maximum capacity. Reduce the flow rate

until water depth stabilizes. This will be the fully primed flow rate for the drain with the connected standpipe diameter. If the drain product fails to prevent air entrainment into the test standpipe, the test shall be terminated.

3.4.10 At fully primed flow, log pressure readings at a sample rate of 100 Hertz, and calculate the average of not fewer than 1,000 readings. The purpose is to account for the characteristically "noisy" static pressure condition in the standpipe due to turbulent flow.

3.4.11 The collected data shall be the measured flow, q , and the static pressures in the standpipe, P_H and P_J . The velocity in the standpipe, V , shall be evaluated using the measured quantities of flow, q , and standpipe inner diameter, d_i , in accordance with Eq. (1)

$$V = 1833 \left(\frac{q}{d_i^2} \right) \quad (1)$$

3.4.12 The static pressure readings at taps (H) and (J) are used to establish the friction loss factor for the vertical standpipe. This value is used for further analysis of the tested drain resistance value. The friction factor, f , is evaluated with Eq. (2)

$$f = \left(\frac{d_i}{h_2} \right) \left(\frac{2g}{V^2} \right) \left(\frac{P_H - P_J}{\rho g} + h_2 \right) \quad (2)$$

3.4.13 The single resistance value, K , shall be evaluated using the pressure readings from both pressure taps at (H) and (J). For pressure tap (H), use Eq. (3)

$$K_H = \frac{\left(h_1 - \frac{P_H}{\rho g} - \frac{V^2}{2g} - f \left(\frac{h_1}{d_i} \right) \frac{V^2}{2g} \right)}{\frac{V_{out}^2}{2g}} \quad (3)$$

3.4.14 For pressure tap (J), use Eq. (4)

$$K_J = \frac{\left((h_1 + h_2) - \frac{P_J}{\rho g} - \frac{V^2}{2g} - f \left(\frac{h_1 + h_2}{d_i} \right) \frac{V^2}{2g} \right)}{\frac{V_{out}^2}{2g}} \quad (4)$$

3.4.15 In Eqs. (3) and (4), V_{out} is referenced to the actual inner diameter of the roof drain spigot outlet, not the inner diameter of the test standpipe.

3.4.16 The values of K calculated at pressure taps (H) and (J) shall not vary by more than 0.05. The published value of K shall be the arithmetic mean of the (H) and (J) values.

3.4.17 Test the drain product with all accessories intended for normal installation, including leaf guards, overflow dams (if applicable), etc.

3.5 Test Apparatus, Depth Versus Flow, Stability, and Speed of Prime

3.5.1 To achieve a steady-state siphonic condition, a certain layer of water around and above the drain air baffle is required in order to prevent the ingestion of air into the piping system and create a closed system.

3.5.2 The testing apparatus for depth versus flow, stability, and speed of prime shall be similar to the test apparatus for single resistance value represented in Fig. 2. However, the standpipe shall have a minimum 40 in. (1 m) clear section (F) for visual observation and an adjustable throttle valve (K) at the standpipe discharge. This valve shall not offer significant resistance when fully open and shall be capable maintaining position without movement during testing. In lieu of a 40 in. section, the entire standpipe may be clear pipe. Refer to Fig. 2.

3.5.3 The standpipe diameter, d_i , shall be the largest diameter intended for installation, i.e., the diameter shall be the largest practicable and capable of developing a fully primed state for the connected drain product while achieving maximum flow capacity of the drain product.

3.5.4 To test stability and speed of prime, the throttle valve (K) shall be fully open. Increase the flow rate slowly until the drain reaches maximum capacity. This will be seen when no air passes through the clear section of tube and water depth begins to rise quickly. The depth where air is excluded will be the water depth at prime. Reduce the flow rate until the water depth stabilizes. This will be the fully primed flow rate for the drain with that particular standpipe diameter.

3.5.5 After establishing the fully primed flow rate, increase the flow rate from zero to maximum flow over a period of 15 sec. Water depth in the tank shall not exceed $\frac{3}{4}$ in. (20 mm) above the steady primed level established in para. 3.5.4 and shall have returned to a steady operating level within a further 5 sec.

3.5.6 The depth versus flow test is conducted by adjusting the throttle valve to achieve a stable water depth on the catchment surface at a given flow. Slowly increase the flow rate until the drain reaches maximum capacity. This will be seen when no air passes through the clear section of tube and water depth begins to rise quickly. The depth where air is excluded will be the water depth at prime. Reduce the flow rate until the water depth stabilizes. This will be the maximum flow rate for the drain. This depth shall be recorded within an accuracy of ± 0.12 in. (± 3 mm) for flow rates ranging from minimum flow to achieve full-bore conditions up to the maximum intended flow capacity. Repeat the flow

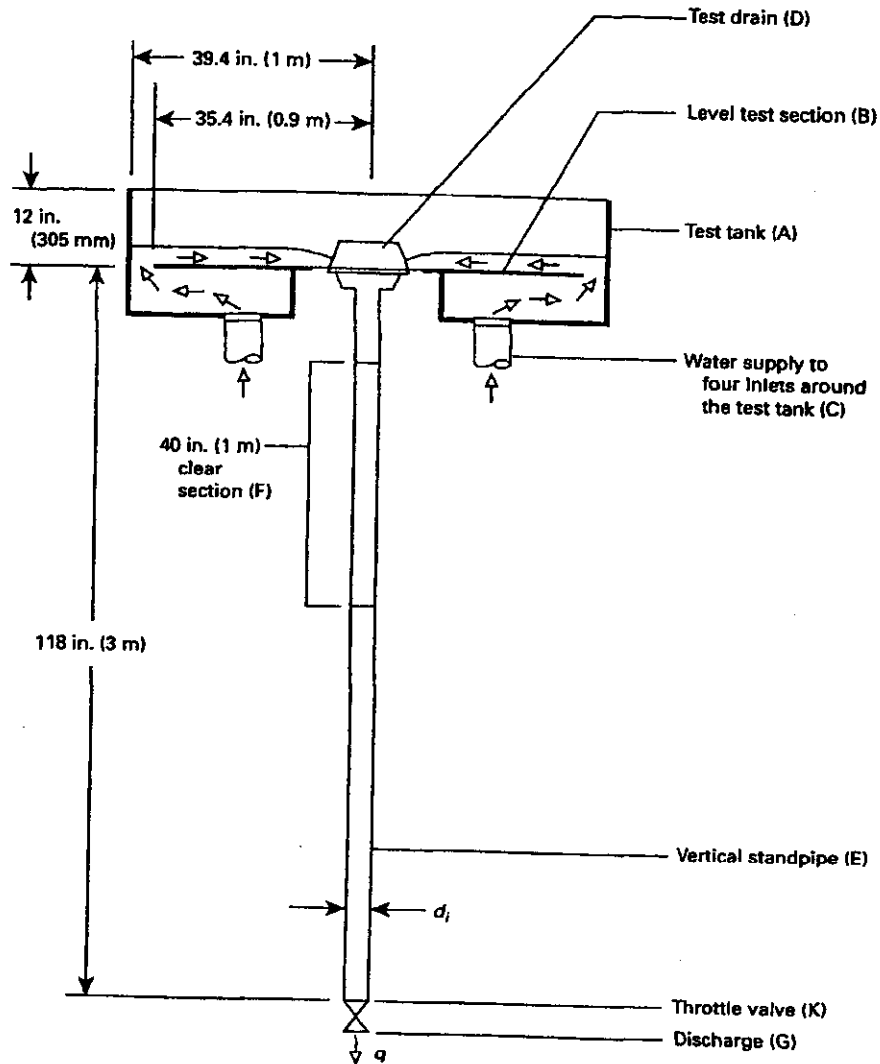

Fig. 2 Depth Versus Flow Apparatus

test several times at varying valve positions to document depth versus flow for the drain over this range.

4 ACCESSORIES

Drain accessories offered by the manufacturer shall comply with para. 6 of ASME A112.6.4

5 MARKINGS

(a) The dome, bodies, and baffle plates shall be marked with the manufacturer's name or trademark.

(b) The baffle plate and drain body shall be marked with the baffle plate model number, resistance value, K , and words, "REPLACE MISSING BAFFLE WITH MODEL _____."

A112 ASME STANDARDS RELATED TO PLUMBING

Air Gaps in Plumbing Systems (For Plumbing Fixtures and Water-Connected Receptors).....	A112.1.2-2004
Air Gap Fittings for Use With Plumbing Fixtures, Appliances, and Appurtenances.....	A112.1.3-2000 (R2005)
Performance Standard and Installation Procedures for Stainless Steel Drainage Systems for Sanitary, Storm, and Chemical Applications, Above and Below Ground.....	A112.3.1-1993
Macerating Toilet Systems and Related Components.....	A112.3.4-2000 (R2004)
Water Heater Relief Valve Drain Tubes.....	A112.4.1-1993 (R2002)
Water Closet Personal Hygiene Devices.....	A112.4.2-2003
Plastic Fittings for Connecting Water Closets to the Sanitary Drainage System.....	A112.4.3-1999 (R2004)
Point of Use and Branch Water Submetering Systems.....	A112.4.7-2002
Manually Operated, Quarter-Turn Shutoff Valves for Use in Plumbing Systems.....	A112.4.14-2004
Floor-Affixed Supports for Off-the-Floor Plumbing Fixtures for Public Use.....	A112.6.1M-1997 (R2002)
Framing-Affixed Supports for Off-the-Floor Water Closets With Concealed Tanks.....	A112.6.2-2000 (R2004)
Floor and Trench Drains.....	A112.6.3-2001
Roof, Deck, and Balcony Drains.....	A112.6.4-2003
Enameled and Epoxy Coated Cast Iron and PVC Plastic Sanitary Floor Sinks.....	A112.6.7-2001
Siphonic Roof Drains.....	A112.6.9-2005
Backwater Valves.....	A112.14.1-2003
Grease Interceptors.....	A112.14.3-2000 (R2004)
Grease Removal Devices.....	A112.14.4-2001
Plumbing Fixture Fittings.....	A112.18.1-2003 (R2005)
Plumbing Fixture Waste Fittings.....	A112.18.2-2002 (R2005)
Performance Requirements for Backflow Protection Devices and Systems in Plumbing Fixture Fittings.....	A112.18.3-2002
Flexible Water Connectors.....	A112.18.6-2003
Deck Mounted Bath/Shower Transfer Valves With Integral Backflow Protection.....	A112.18.7-1999 (R2004)
Enameled Cast Iron Plumbing Fixtures.....	A112.19.1M-1994 (R2004)
Vitreous China Plumbing Fixtures and Hydraulic Requirements for Water Closets and Urinals.....	A112.19.2-2003
Stainless Steel Plumbing Fixtures (Designed for Residential Use).....	A112.19.3-2000
Porcelain Enameled Formed Steel Plumbing Fixtures.....	A112.19.4M-1994 (R2004)
Trim for Water-Closet Bowls, Tanks, and Urinals.....	A112.19.5-1999
Hydraulic Performance Requirements for Water Closets and Urinals.....	A112.19.6-1995
Whirlpool Bathtub Appliances.....	A112.19.7M-1995
Suction Fittings for Use in Swimming Pools, Wading Pools, Spas, Hot Tubs, and Whirlpool Bathtub Appliances.....	A112.19.8M-1987 (R1996)
Non-Vitreous Ceramic Plumbing Fixtures.....	A112.19.9M-1991 (R2002)
Dual Flush Devices for Water Closets.....	A112.19.10-2003
Wall Mounted and Pedestal Mounted, Adjustable and Pivoting Lavatory and Sink Carrier Systems.....	A112.19.12-2000 (R2004)
Electrohydraulic Water Closets.....	A112.19.13-2001
Six-Liter Water Closets Equipped With a Dual Flushing Device.....	A112.19.14-2001
Bathtubs/Whirlpool Bathtubs With Pressure Sealed Doors.....	A112.19.15-2005
Manufactured Safety Vacuum Release Systems (SVRS) for Residential and Commercial Swimming Pool, Spa, Hot Tub, and Wading Pool Suction Systems.....	A112.19.17-2002
Qualification of Installers of High Purity Piping Systems.....	A112.20.1-2004
Qualification of Installers of Firestop Systems and Devices for Piping Systems.....	A112.20.2-2004
Floor Drains.....	A112.21.1M-1991 (R1998)
Roof Drains.....	A112.21.2M-1983
Hydrants for Utility and Maintenance Use.....	A112.21.3M-1985 (R2001)
Cleanouts.....	A112.36.2M-1991 (R2002)

The ASME Publications Catalog shows a complete list of all the Standards published by the Society. For a complimentary catalog, or the latest information about our publications, call 1-800-THE-ASME (1-800-843-2763).

ASME A112.6.9-2005

ISBN 0-7918-2970-7



9 780791 829707



J17205