

CODE LINK

STATE OF OREGON • BUILDING CODES DIVISION

MAY/JUNE 2000

Amusement ride program explained



One of BCD's little-known, but very important, safety programs is the amusement ride program. The division issues annual operating permits, follows up on compliance issues, and maintains files on permitted rides and amusement ride companies.

Although few rides operate year-around, March generally marks the beginning of the ride season, when companies bring their rides out of winter quarters to operate at malls, fairs, and festivals. The following questions are frequently asked:

Question

Is this company or ride required to have a permit?

Answer

Any ride or device as defined in ORS 460.310 is required to have a permit, including the following:

- structures, electrical, or mechanical contrivances, or combination thereof, intended to supply revenue to the owner or operator of the device by providing or offering to provide amusement, pleasures, thrills, or excitement at carnivals, fairs, or amusement parks.

Please see "Amusement ride," Page 9

New DCBS director named.....	2
BCD reorganizes	2
FEMA director supports building codes	3
Tri-County Service Center update	3
Electrical and Mechanical Board Consolidation Task Force to meet.....	4
Deadlines for continuing education for Oregon certificants.....	5
Masonry exhaust stack collapses	5
Manufactured structures and parks Q & A	6
Dangerous products recalled.....	7
Stakeholder meetings lead to committee action	8
Editorial corrections to dwelling code table	10
Company recalls Star brand fire sprinklers manufactured from 1961 to 1976	11
Compliance Report	12
Interpretive rulings signed.....	14
History of building codes adoptions	15
New managers named.....	16
DOGAMI publications available	16
Administrative rules filed	16
Board vacancies	17
1999 administrative rules offered on line ..	18
SB587 licensing and timeline workshops scheduled	18
Licensing and timeline workshops scheduled	18
Plumbing amendment packet notice	18
Stakeholder meetings scheduled	20

New DCBS director named



Mary Neidig

Mary Neidig, former administrator of the Workers' Compensation Division, has been named director of the Department of Consumer and Business Services. Neidig

replaces Mike Greenfield, who left the agency to become the director of the Department of Administrative Services.

Neidig became the WCD administrator in 1996 and was responsible for the administration and enforcement of workers' compen-

sation laws. She served as chair of the Workers' Compensation Board from 1991 to 1996 and worked as a human resource manager for various wood products companies.

As DCBS director, Neidig will oversee the state's largest regulatory and consumer protection agency. DCBS regulates insurance, financial institutions, securities, building codes, occupational safety and health, workers' compensation, and real estate appraisers. ■

BCD reorganizes

BCD is undergoing some organizational changes to be more responsive and to improve the consistency of information provided to our customers. We will accomplish this by creating chief positions in each program area (electrical, plumbing etc.) that have responsibility for decisions in code interpretation, rule development, compliance, licensing, and jurisdictional reviews. These changes are being made in response to concerns raised at our stakeholder meetings, task groups, and customer feedback surveys.

Specifics of the changes include:

Establish chief inspector positions for all program areas: electrical (Gary Wilson); plumbing (Terry Swisher); elevator (Jim Runyan); boiler (Curt Lundine); manufactured structures, RVs and parks (Pat Lewis); building code administration, formerly State Building Official (Peggy Collins); and structural/mechanical (vacant). By consolidating functions within each program, we will have experts available to address concerns and

inquiries regarding code interpretation, licensing, etc. This should result in more timely and consistent responses.

BCD is restoring staff in the structural program to provide experts to assist jurisdictions and the public with building design and construction issues. Staff will be available to assist with accessibility, fire and life safety, residential dwelling, mechanical, and other building code-related issues.

Jurisdictional review will remain an important function within the division. Teams of experts will be established based on the nature of the review, the scope of the issues, and the size and/or complexity of the jurisdiction's program to provide better service to jurisdictions as they administer the statewide code.

BCD will be implementing these changes over the next several months and anticipates completion by July 1. Questions about our restructuring can be directed to Dana Roberts or Mark Long, (503) 378-4133. ■

Tri-County Service Center update

by Joanie Stevens-Schwenger



Thanks to the hard work and dedication of the Tri-County Building Industry Service Board, the Tri-County Service Center will open on schedule July 1. The Service Center, located at 123 NE Couch, Suite 440, Portland, will administer the plumbing and electrical minor label programs for the tri-county region.

Board committees are currently working to develop programs and functions for the center, including coordination of training for inspectors and plans reviewers and facilitation of consistent code interpretation in the 27 jurisdictions of the tri-county region.

Board Chairman Lisa Naito, at a recent appearance before the House Committee on General Government, said that she had expected that she would be asking the committee for an extension due to the amount of work the committees had to accomplish.

"The building officials and industry representatives have established such a positive working relationship that many of the board's

projects are speeding along ahead of schedule," said Naito.

In addition to the minor label program, the board has recently approved administrative rules defining standardized fee methodologies and permit application forms. The Forms and Processes Committee is forwarding four application forms, a one- and two-family dwelling checklist, and proposals to standardize issuance of "over-the-counter" permits and recording inspections to the board.

"We see this as a very successful beginning," noted Clint Hilman, building official for the City of Gresham and chairman of the Forms and Processes Committee. "Industry and building officials on the committee have earmarked a number of issues and processes that we've all agreed to tackle. Within a year, industry will find a number of processes streamlined and standardized."

The grand opening of the center will take place after the July 12 board meeting. Details of the event will be in the next *CodeLink*. ■

FEMA director supports building codes



In a letter to Governor Kitzhaber, James L. Witt, director of the Federal Emergency Management Agency, stated that FEMA has made prevention the focus of emergency management in the U. S. He said: "Strong, rigorously enforced building codes are central to that focus. When disaster strikes, no matter where or how, building codes and standards are the front line of defense. The positive impacts of building codes and standards can be seen in every type of disaster. Communities that have strong, well-enforced codes and standards pick up the pieces and recover. Communities with weak, non-existent, or poorly enforced codes and standards struggle to recover. Tragically, some never fully recover."

FEMA has worked with national building codes and standards-writing organizations to ensure that the technical lessons of disasters are shared.

Recent changes to FEMA disaster assistance regulations benefit communities that choose up-to-date building codes before disaster strikes. FEMA will share the costs associated with state and local repair and replacement codes or standards only if those construction codes are reasonable, in writing, and have been formally adopted and implemented by the state or local government prior to the Presidential disaster declaration. ■

Electrical and Mechanical Board Consolidation Task Force to meet



SB 803, from the 1999 Legislative Session, created an Electrical and Mechanical Board Consolidation Task Force to study consolidating the roles and responsibilities of the Board of Boiler Rules, the State Plumbing Board, and the Electrical and Elevator Board into a single board and transferring certain duties from the Building Codes Structures Board.

The governor has appointed four members from each of the affected boards and one member at large to serve on the task force:

Electrical and Elevator Board:

Walter E. Conner, IBEW Local 659
Keith Edwards, IBEW Local 48
Eugene Morgan, Clackamas County
Nathan Philips, Philips Electric

State Plumbing Board:

Lewis E. Seagraves, Seagraves Consulting
Perry G. Shinn, Fullman Kinetics
Ken Carlson, City of Portland
Robert J. Kimes, UA Local 290

Board of Boiler Rules:

Rodger Vignery Jr., McDowell Welding and PipeFitting
Steve J. Nelson, International Brotherhood of Boilermakers, Local 500
John M. Endicott, UA Local 290
Michael H. Gibson, Lochmead Farms Inc.

Building Codes Structure Board:

John A. Talbott, Talbott Assoc. Inc.
Michael S. Broomfield, City of Ashland
Jim A. Schwager, Portland Bureau of Fire, Rescue & Emergency Services
David D. Walter, Housing Authority of Portland

Member at large:

Bob Shiprack, Oregon State Building and Construction Trades Council

The first meeting of the task force is scheduled for 9 a.m., Wednesday, May 3, at BCD, in Conference Room A. Meetings will be held every four weeks through November. ■

Deadlines for continuing education for Oregon certificants



Plans examiners and inspectors are required to attend continuing education classes. According to OAR 918-098-0460, certificants are required to obtain at least six hours (12 hours, if multiple-certified) of continuing education credit related to their duties as inspectors and plans examiners annually. In code-change years, inspectors and plans examiners must attend a division-approved code-change class within 12 months of the effective date of the new code.

The mechanical code changed October 1, 1999. Mechanical inspectors (A and B levels) need to complete a code-change class by October 1, 2000. The one- and two-family dwelling, plumbing, and electrical codes changed April 1, 2000. All one- and two-family dwelling inspectors and plans ex-

aminers need to obtain code-change credits by April 1, 2001. Electrical inspectors are required by OAR 918-281-0010 to obtain code-change credit within six months (October 1, 2000) and plumbing inspectors are required by OAR 918-695-0400 to obtain code-change credit within nine months (January 1, 2001) in order to satisfy the continuing education requirements. The certificates of those who do not complete the required classes will lapse; notification will be sent to certificants 60 days before that occurs.

Visit our Web site, www.cbs.state.or.us/bcd, for more information about continuing education. ■

Masonry exhaust stack collapses

In February, a seven-story exterior boiler exhaust stack collapsed in LaGrande, Ore. The stack, weighing many tons, fell in upon itself, also destroying part of an adjacent structure.

The exhaust stack, built in 1912, was two courses of standard clay brick attached to the outside of a large retail and residential building. For many years, the boiler to which the exhaust stack was attached burned coal or heavy oil. Both of these fuels contain sulfur compounds. When the fuel is burned, the sulfur compounds remain in the exhaust gas and can adhere to the inside of an exhaust stack when combined with soot or fly ash. If not routinely removed, sulfur can form a weak sulfuric acid solution that attacks the mortar bond between the bricks in the stack.

The cause of the collapse of the structure in LaGrande is unknown, but the remaining mortar on the brickwork has very little bond remaining; it can easily be removed from the bricks by hand. If the mortar formula used by the original builders in 1912 was proper for the application, one can assume that an unforeseen condition caused erosion and weakening of the mortar.

Masonry boiler exhaust stacks from the same era as the LaGrande stack are in use in many public buildings in Oregon. Is there need for inspection of these structures? What is the potential for similar problems in other boiler stacks? What is the level of hazard to Oregonians? These and other questions should be considered by public safety officials in Oregon. ■

Manufactured structures and parks Q & A

By Patrick Lewis



In each publication, we attempt to answer questions on a variety of issues regarding the manufactured structures and parks programs. This issue will be devoted to the construction of recreational vehicle parks.

Question

I have a 1993 edition of the recreational parks and organizational camps administrative rules (OAR 918-650). Is this still current or has it been replaced with a newer edition?

Answer

The 1993 edition is the most current. However, the division is preparing to update these rules and is appointing a task force to work on this project.

Question

Are toilet facilities required in all recreational vehicle (RV) parks?

Answer

Yes. OAR 918-650-0050(1) requires toilet facilities in every RV park.

Question

Doesn't OAR 918-650-0050(1) exempt toilet facilities when each RV park space contains a sewer connection for an RV?

Answer

No. OAR 918-650-0050(1) only exempts the requirement for toilet facilities to be within 500 feet of each recreational vehicle space, but it does not exempt the RV park from the toilet-facility requirements.

Question

Doesn't ORS 446.340(3) exempt toilet facilities in RV parks when a dump station is provided?

Answer

No. ORS 446.340 only states that the division cannot require both toilets and dumping stations. Dumping stations are only provided at the option of the park owner for the convenience of the park owner's customers. Because the division does not require dump stations, this law does not exempt the requirements for toilets.

Question

How many toilets are required in an RV park?

Answer

Table 2 of OAR 918-650-0050 establishes the number of toilets based on the number of spaces in the park. For instance, if a park has 31 spaces, two toilets for men and three toilets for women would be required according to the table.

Question

Can unisex toilets be used in RV parks?

Answer

Yes. OAR 918-650-0050(2)(e) allows unisex toilets to be used provided the occupant load is 15 persons or less. If the occupant load is more, multiple unisex toilets may be used. There would have to be a minimum of two unisex toilets available in the RV park and each one would have to be equipped with a urinal.

Question

Can toilet facilities in an RV park be locked at night?

Answer

No. The only time the toilet facilities can be locked is when the park is closed and not occupied.

Question

Can some of the toilet facilities be locked during the off-season to cut down on maintenance?

Answer

Yes. Some toilet facilities could be locked as long as enough toilet facilities are left open to serve the off-season occupant load, based on Table 2 of OAR 918-650-0505. For example, if the RV park has 50 spaces, but only 15 are occupied, the park owner

could lock all but one facility for each sex, notwithstanding the 500-foot limitation to each RV space where applicable.

Question

Can portable toilet facilities be used in a permanent RV park?

Answer

Yes. Chemical toilets, vault toilets, or pit privies may be used in RV parks as long as they comply with the minimum requirements of DEQ. ■

Dangerous products recalled

From *The Gated Wye*



Power strips recalled

Champion Power Strips-Frieder Inc. is recalling 35,000 Champion Brand Tools six-outlet, 125-volt power strips made in China. They show no UL listing and have a manufacture date of 4/97. Writing on the cord reads “Chang RVV 300/500V.” “Champion Quality Tools” and “10741” appear on the package. The wiring in these power strips is undersized and poses shock and fire hazards.

Consumers should stop using these items and return them to the seller for a refund or send them to Frieder for a refund plus postage. Call Frieder, (800) 321-8192.

Ceiling light fixtures recalled

TSI Prime Inc. is recalling about 126,000 ceiling-mounted light fixtures. The fixtures can

short-circuit, posing a fire hazard. TSI Prime has received reports of these fixtures short-circuiting, resulting in scorch marks on ceilings.

The recall involves a four-bulb, flush-mount ceiling light fixture. The fixture has an eight-sided glass and brass enclosure. A sticker on the fixture near the base of one of the light sockets reads: “MADE IN CHINA,” and “E181045.” If the light fixture has the E181045 number, call TSI Prime to see if it’s part of the recall.

Consumers should stop using these lights and call TSI Prime toll-free, (877) 317-9237 for a free replacement. ■

Stakeholder meetings lead to committee action

by Joan Fraser, Deputy Administrator



In October 1999, a series of stakeholder meetings were held around the state to gather information about how the building code system operates in Oregon and possible improvements. Areas of interest common to most stakeholders:

- assumption process and fees
- compliance process
- consistency of code interpretation, code adoption, plan review, and overall timeliness of service
- partnerships between local and state jurisdictions, industry, and regulators, other governmental entities and building regulators
- certification and licensing
- BCD issues such as use of technology, code expertise, and leadership in enforcement
- boards and how they operate

The department appointed a steering committee December 10, 1999, representing plumbing contractors, plumbers, electrical contractors, electricians, city officials, remodelers, design professionals, architects, homebuilders, city building officials, county building officials, general contractors, mechanical engineers, consumers, and state regulators. The steering committee has met four times to articulate problem statements and policy questions around the seven issues raised at the stakeholder meetings. The committee has also reviewed the compliance program, including changes proposed by staff. The committee identified what members believe to be the purpose of compliance, the policies and principles upon which the program needs to be based; the goals of the program; and the results that can be expected. These are as follows:

Compliance Program

Purpose

- To protect the health and safety of the people of Oregon by ensuring that rules and standards are complied with through education and enforcement.

Policy and Principles

- The cost of not complying must be more than the cost of complying.
- Emphasis must be on education and understanding.
- Given adequate resources, regulations, and oversight, local jurisdictions must be involved in compliance.
- Licensing and permitting should be standardized across trades.

Goals

- Establish a compliance process that is uniform, consistent, and fair.
- Ensure compliance with the applicable codes, rules, and statutes in a timely manner.
- Protect the health and safety of the people of Oregon.
- Make compliance the best option to continue working
- Develop local jurisdictions' confidence in the division's compliance program.
- State has the ultimate responsibility for compliance.

Results to be achieved by an ideal program

- Local jurisdictions will be more involved in the compliance process. This will make compliance more effective. All violators will initially be treated in an equal manner.
- Paperwork will be reduced.
- Time to process a case will be reduced.
- Number of requests for hearings will be reduced; number of cases resolved informally will be increased.
- Number of cases needing investigation will be reduced.
- Consequences of specific violations will be predictable.
- Safety issues will have highest priority.
- There will be more voluntary compliance.
- More training will be provided to state and local inspectors.
- Common licensing standards will exist.
- There will be clear expectations for all players.
- The system will be simple and uniform, with no conflicting messages.

The committee's goal is to finish a work plan and reach consensus on recommendations for both administrative and legislative changes. The committee will report on these issues to the legislature next fall. ■

Amusement ride, *continued*

- vehicles, boats, or other mechanical devices (except water slides) moving upon or within a flow perimeter or structure, along cables, rails or ground, through the air by centrifugal force or otherwise, or across water, that is used to convey one or more individuals for amusement, entertainment, diversion, or recreation.

Question

What are the requirements to obtain a permit?

Answer

Owners and operators of amusement rides and devices operating in Oregon are required to provide the division with certificates of insurance covering their rides. Each ride must have a safety inspection by an inspector authorized by the insurance carrier, who also meets the standards established in OAR 918-

200-0095. Each company must submit to BCD a permit application with the inspection report and a \$25 permit fee for each ride.

Question

How do I know if a ride has a permit?

Answer

OAR 918-200-0025 requires the permit to be posted in an accessible and visible location on each ride. The permits are 5" x 5" metal tags and are issued in a different color each year. Jurisdictions are reminded that amusement ride operators cannot legally operate rides until valid permits are issued and posted on the rides. Owners should begin the permit process well in advance of planned operation.

Call (503) 378-4133 with questions about Oregon's amusement ride program. ■

Editorial corrections to dwelling code table



Following is a new Table 404.1.1(1) to replace the one in the 2000 International One- and Two-Family Dwelling Specialty Code.

TABLE 404.1.1(1)

PLAIN CONCRETE AND MASONRY FOUNDATION WALLS ^a

Maximum wall height (feet)	Maximum unbalanced backfill height ^e (feet)	Plain concrete minimum nominal wall thickness (inches)			Plain masonry ^c minimum nominal wall thickness (inches)		
		Soil classes ^d					
		GW, GP, SW AND SP	GM, GC, SM SM-SC and ML	SC, MH, ML-CL and inorganic CL	GW, GP, SM and SP	GM, GC, SM, SM-SC, and ML	SC, MH, ML-CL and inorganic CL
5	4	6	6	6	6 solid ^f or 8	6 solid ^f or 8	6 solid ^f or 8
	5	6	6	6	6 solid ^f or 8	8	10
6	4	6	6	6	6 solid ^f or 8	6 solid ^f or 8	6 solid ^f or 8
	5	6	6	6	6 solid ^f or 8	8	10
	6	6	8 ⁱ	8 ⁱ		10	12
7	4	6	6	6	6 solid ^f or 8	8	8
	5	6	6	8 ⁱ	6 solid ^f or 8	10	10
	6	6	8	8	10	12	10 solid ^f
	7	8	8	10	12	10 solid ^f	12 solid ^f
8	4	6	6	6	6 solid ^f or 8	6 solid ^f or 8	8
	5	6	6	8	6 solid ^f or 8	10	12
	6	8 ⁱ	8	10	10	12	12 solid ^f
	7	8	10	10	12	12 solid ^f	Note ^g
	8	10	10	12	10 solid ^f	12 solid ^f	Note ^g
9	4	6	6	6	6 solid ^f or 8	6 solid ^f or 8	8
	5	6	8 ⁱ	8	8	10	12
	6	8	8	10	10	12	12 solid ^f
	7	8	10	10	12	12 solid ^f	Note ^g
	8	10	10	12	12 solid ^f	Note ^g	Note ^g
	9	10	12	Note ^h	Note ^g	Note ^g	Note ^g

Company recalls Star brand fire sprinklers manufactured from 1961 to 1976



In cooperation with the U.S. Consumer Product Safety Commission (CPSC), Mealane Corp. of Philadelphia, PA, is voluntarily recalling Star brand fire sprinklers manufactured from 1961 through 1976.

These sprinklers could fail in a fire, exposing the public to bodily injury or death. These sprinklers have been primarily installed in nursing homes and hospitals. They may also be found in schools, warehouses, cold-storage areas in supermarkets nationwide, and on loading docks. The Star sprinklers being recalled are “dry-type” models **D-1, RD-1, RE-1, E-1, and ME-1**. The name “Star” appears on the sprinkler, along with the model number and date of manufacture. With “dry-type” sprinklers, portions of the pipe do not have water in them until the sprinkler activates.

Mealane Corporation urges consumers and property owners to see if their buildings contain Star D-1, RD-1, RE-1, E-1, and ME-1 sprinkler models made from 1961 to 1976 and to call the Star Sprinkler Recall Hotline, (800) 866-7807, or visit the Web site, www.star-recall.com, for more information.

PENDANT AND UPRIGHT

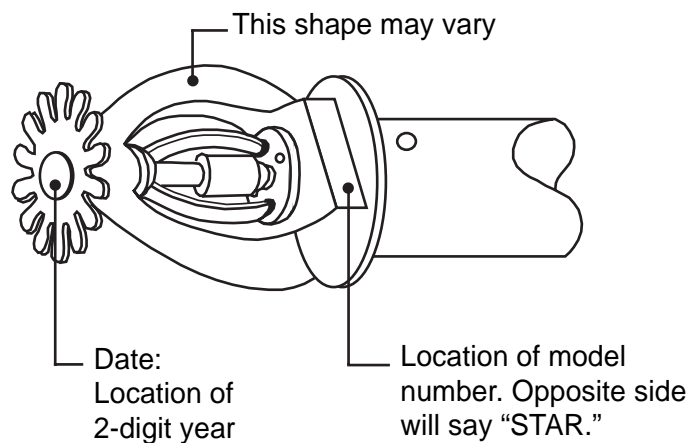

VERTICAL SIDEWALL

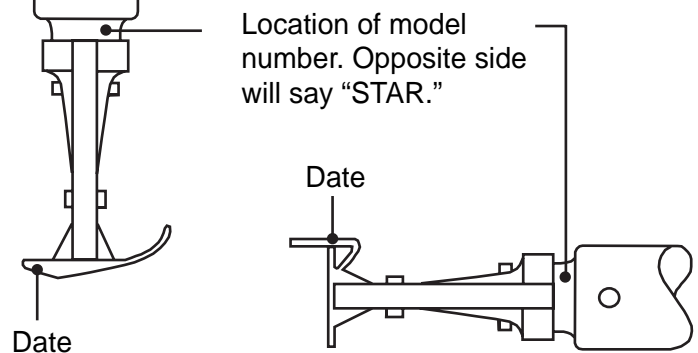

HORIZONTAL SIDEWALL

There are four styles of sprinklers:

- Pendant
- Upright
- Vertical sidewall
- Horizontal sidewall

The following model numbers may appear on any recalled sprinkler style:

D-1
RD-1
RE-1
E-1
ME-1

Compliance Report

The Building Codes Division is responsible for the enforcement of Manufactured Dwellings and Structures, Plumbing, Structural/Mechanical, Electrical and Boiler/Pressure Vessel Specialty Codes to protect the health and safety of the people of Oregon.

The Director of the Department of Consumer and Business Services found the following violations of the Oregon Specialty Codes in March 2000:

CITY	NAME	VIOLATION	CIVIL PENALTY ASSESSED
Bend	David Mark McKinley Deschutes Plumbing	No plumbing permit	\$250
Brookings	Mike Rupert	No building permit	\$250
Lakeview	Ken Van Hoesen Lakeview Plumbing & Supply	No plumbing permit (3 violations)	\$750
McMinnville	Jose Perez	No plumbing permit	\$250
Portland	Oak Hill Roofing Inc.	No building permit	\$250
Powers	Jack Humbert	No building permit	\$250
Prineville	Craig Forney	No building permit	\$250
Orlando, FL	Gencor Industries Inc.	No prefab insignia of compliance	\$250

The Director of the Department of Consumer and Business Services found the following violations of the regulation of manufactured dwellings and amusement rides in March 2000:

CITY	NAME	VIOLATION	CIVIL PENALTY ASSESSED
Lebanon	Alan Edward Roth Alan Roth Construction	No manufactured dwelling installer's license/no certification tag	\$750
Portland	Roger Casey Kid-A-Ride Amusement	No amusement ride operating permits (18 violations)	\$9,000

The Plumbing Board found the following violations of the Oregon Plumbing Specialty Code in February 2000:

CITY	NAME	VIOLATION	CIVIL PENALTY ASSESSED
Albany	John Richard Hoby dba JR Hoby Plumbing	Allowed an unlicensed individual to make a plumbing installation	\$500
Bend	Jason Lloyd Hoby	No plumbing journeyman's certificate of competency	\$500
Eugene	Peter Abbatello	No plumbing journeyman's certificate of competency	\$500

Eugene	V-Tec Plumbing & Heating, Inc.	Allowed an unlicensed journeyman's individual to make a plumbing installation	\$500
Gold Beach	Don Goff	No plumbing journeyman's certificate of competency/no plumbing permit	\$1,000
Lakeview	Ken Van Hoesen	No plumbing business certificate of registration	\$2,000
	dba Lakeview Plumbing & Supply		
Roseburg	A.C. Plumbing, Inc.	Allowed an unlicensed individual to make a plumbing installation	\$500
Roseburg	Olin N. Vermillion	No plumbing journeyman's certificate of competency	\$500
Selma	Alexander Louis Grillo	No plumbing business certificate of registration	\$500
	dba Alexander Construction		

The Electrical and Elevator Board found the following violations of the Oregon Electrical Safety Law in February 2000:

CITY	NAME	VIOLATION	CIVIL PENALTY ASSESSED
Corvallis	Robert K. Alexander	No electrical supervising or journeyman's license/ no electrical permit	\$750
Grants Pass	Siro Bignotti	No electrical contractor's license	\$500
	Audio Visual Equipment Repair		
Grants Pass	Quinn's Well Drilling Inc.	No electrical permit	\$250
Hermiston	Peterson Electric Inc.	Allowed unlicensed individual to make electrical installation (2 violations)	\$1,000
Merlin	Brian T. Ugstad	No electrical supervising or journeyman's license	\$500
Metolius	Richard David Cooley	No electrical supervising or journeyman's license	\$500
Portland	Neal Alston	No electrical contractor's license/ /no supervising or journeyman's license/ no electrical permit	\$1,250
	Drain Master Plumbing		
Portland	Step-Saver Inc.	Installed elevator without prior plan approval (2 violations)	\$500
Selma	Alexander Louis Grillo	No electrical supervising or journeyman's license/ no electrical permit	\$750
	Alexander Construction		
Fremont, CA	DataTech Systems Inc.	No electrical contractor's license/no electrical permit	\$750
Brush Prairie, WA	Eugene Guyton	No electrical contractor's license/no electrical supervising or journeyman's license/no electrical permit	\$1,250
	Caprocorn Heating, Air Conditioning & Custom Sheet Metal		
Tacoma, WA	Gary Wells	No electrical supervising or journeyman's license	\$500
Vancouver, WA	Comwerx Inc.	Allowed unlicensed individual to make electrical installation/ no electrical permit	\$750

The Board of Boiler Rules found the following violations of the Oregon Specialty Codes in March 2000:

CITY	NAME	VIOLATION	CIVIL PENALTY ASSESSED
Portland	Total Mechanical, Inc.	No installation permit (3 violations)	\$3000
Vancouver, WA	BOC Gases	No installation permit	\$500
Vancouver, WA	Town & Country Heating, Inc.	No boiler/pressure vessel business license/ no installation permit (2 violations)	\$1,500

Interpretive rulings signed

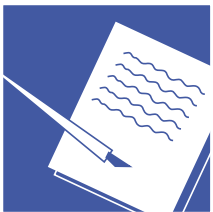

The following plumbing-product approvals were signed by the Plumbing Board chairman and the division administrator in February. Copies were sent to building officials and can be found on our Web site, <http://www.cbs.state.or.us/bcd>.

- 00-1 Gibson Steel Fabricating Inc. steel catch basin
- 00-2 Beko's Weld-N-Wood steel catch basin
- 00-3 Belco Manufacturing Inc. steel catch basin
- 00-4 Gratemaster Iron Works steel catch basin
- 00-5 The Lynch Co. steel catch basin
- 00-6 Utility Vault Company Inc. concrete catch basin
- 00-7 The Willamette Mfg. & Supply Co. steel catch basin

The following interpretive rulings have been rescinded:

- 92-24 Plans on the Job Site
- 93-14 Drinking Fountains by Occupancy and Use
- 93-31 Window wells as basement bedroom egress windows in one- and two-family dwellings and apartments
- 93-34 Code required certifications
- 93-36 Special inspector certification
- 93-54 Exiting from floors above the first floor
- 93-63 Required Grades of Wood Shingles and Shakes
- 93-66 Shafts for Metal Chimneys
- 93-67 Measure Clear Opening of Required Doorways
- 93-71 Moving and Change of Occupancy of Prefabricated Structures and Mobile Homes
- 94-15 Flameproof defined

History of building codes adoptions



The following is a chronology of uniform building codes adopted by the State of Oregon from code books in the division. We believe it accurately identifies each code and its effective date.

Uniform Building Code (UBC)

Edition	Effective date
1973	July 1, 1974
1976	March 1, 1978
1979	July 1, 1980
1982	August 1, 1983
1985	July 1, 1986
1988	January 1, 1990
1991	January 1, 1993
1994	April 1, 1996
1997	October 1, 1998

Uniform Plumbing Code (UPC)

Edition	Effective date
1973	February 1, 1975
1976	January 1, 1978
1979	July 1, 1981
1980 (based on 1979)	October 13, 1984
1985	January 1, 1987
1988	January 1, 1990
1991	February 1, 1992
1994	April 1, 1996
1997	April 1, 2000

National Electric Code (NEC)

Edition	Effective date
1968	January 1, 1969
1971	May 1, 1972 (estimated)
1975	July 1, 1975
1978	January 1, 1978
1981	October 1, 1981
1984	July 1, 1984
1987	May 1, 1987
1990	July 1, 1990
1993	July 1, 1993
1996	October 1, 1996
1999	April 1, 2000

Uniform Mechanical Code (UMC)

Edition	Effective date
1973	July 1, 1974
1976	March 1, 1978
1979	July 1, 1980
1982	August 1, 1983
1985	May 1, 1986
1988	January 1, 1990
1991	January 1, 1993
1994	April 1, 1996

International Mechanical Code

Edition	Effective date
1998	October 1, 1999

One- & Two-Family Dwelling Code (CABO)

Edition	Effective date
1983	May 1, 1986
1986	Not adopted
1989	April 1, 1990
1992	May 1, 1993
1992	modified April 1, 1995
1995	April 1, 1996
Electrical NEC 70A	April 1, 1990
Electrical NFPA 70	April 1, 1996
1998 International I and z	April 1, 2000

International One- & Two-Family Dwelling Code

Edition	Effective date
1998	April 1, 2000

New managers named



Nanci Johnston has been named the eastern field manager for Field Operations and will be stationed in the Pendleton field office starting July 1. She will manage field offices in Pendleton, Enterprise, Lakeview, and The Dalles. Johnston was the division safety coordinator and special projects coordinator for the Field Operations Section.

Brad Finch became western field manager for Field Operations effective

February 14 and is stationed in Coquille. He has held various plant management positions, including 18 years with JELD-WEN, a Klamath Falls-based window and door manufacturer. Finch holds a bachelor's degree in business administration and an associate degree in electrical engineering technology. He will oversee the Coquille field office and the Lane, Douglas, Clatsop, Coos and Curry county offices. ■

DOGAMI publications available



Two new publications from the Oregon Department of Geology and Mineral Industries are designed to give policy makers and the general public better tools to reduce the toll of geologic processes on people and property.

Mitigating geologic hazards in Oregon: A technical reference manual (Special Paper 31) includes information on Oregon's past disasters, potential for future problems, issues to address when more than one hazard is present (i.e., flooding and landslides), and a variety of mitigation strategies. It is designed

primarily for planners, emergency managers, and policy makers.

Geologic hazards: Reducing Oregon's losses (Special Paper 32) is a summary of a technical manual, with photographs, and is designed for nontechnical users.

For more information on these publications and the department's current projects, contact James Roddey, 800 NE Oregon St., Portland OR 97232, or call (503) 731-4100, ext. 242. ■

Administrative rules filed



The following permanent rules have been filed:

- Converting a temporary rule adopting rules of procedure for lay representation for corporations
- Converting a temporary rule adopting mechanical plan review fees
- Reaffirming adoption of the 1997 Uniform Plumbing Code with Oregon amendments effective April 1
- Adopting minimum safety standards for workmanship and materials for design

and construction of electrical products used in traction electrification and electrical communications and signaling installations for rail fixed guideway systems operated by a mass transit district (implements 1997 Senate Bill 147)

Copies of these rules were mailed to all building officials. They can also be viewed on the Web at <http://arcweb.sos.state.or.us/banners/rules>. Refer questions to Louann Rahmig, rules coordinator, (503) 373-7438. ■

Board vacancies for 2000



Listed are vacancies occurring in 2000 on Building Codes Division boards. All positions are four-year terms. The director appoints the Manufactured Structures and Parks Advisory Board members; the governor appoints all others.

Board of Boiler Rules (both expire September 15)

Mechanical engineer
Boilermaker

Building Codes Structures Board (all expire June 30)

Architect
Homebuilder
Disabilities commission representative
Public member

Electrical and Elevator Board (all expire June 30)

Journeyman electrician
Electrical equipment manufacturer
Journeyman elevator installer
Public member

Manufactured Structures and Parks Advisory Board

Accessory structures manufacturer/sales - expires June 30
Manufactured home sales - expires June 30
Consumer organization - expires June 30
Local government building official - expires June 30
Mobile home/manufactured dwelling or recreation park - expires June 30
RV sales - expires June 30
RV manufacturer - expired September 30, 1999

Plumbing Board (both expire June 30)

Mechanical engineer
Health division

Tri-County Building Industry Service Board (all expire June 30)

Architect/engineer
Labor organization, construction trades
Elected city official
General contractor

1999 administrative rules offered on line



Find 1999 BCD rules at <http://arcweb.sos.state.or.us/banners/rules>. The Archives Division, Administrative Rules Section, is updating the compilation monthly, so permanent rules filed by the fifteenth of each month will appear in the compilation on the

first of the following month. Rules filed also appear in the *Oregon Bulletin* the first of the following month. Questions may be directed to Louann Rahmig, rules coordinator, (503) 373-7438. ■

Licensing and timeline workshops scheduled

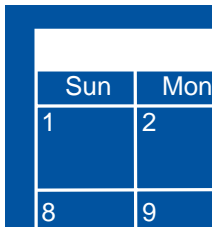

These workshops are scheduled to educate the public and local jurisdictions on how the licensing and timeline provisions of SB 587 will affect them.

DATE	TIME	LOCATION*
5/31/00	1:30 p.m.	Bend
6/5/00	1:30 p.m.	Grants Pass
6/6/00	10:00 a.m.	Eugene
6/8/00	1:30 p.m.	Pendleton
6/14/00	1:30 p.m.	Portland

*Workshop addresses will be announced; check BCD's Web site for updates.

Questions regarding the workshops should be directed to Nanci Johnston, (503) 378-5838, Mark Long, (503) 373-1227, or Bill Cross, OBOA (503) 873-1157. Requests for copies of the materials to be presented at the workshops should be directed to Louann Rahmig, (503) 373-7438. Send e-mail to louann.p.rahmig@state.or.us. ■

Notice

The plumbing chapters of the One- and Two-Family Dwelling Specialty Code are available at the usual outlets.

The Chapter 49 yellow pages in the plumbing amendment packet need to be **added to** the white (model code) pages in Chapter 49. The standards that came with the plumbing packet are a list of **plumbing standards** adopted by the State of Oregon. The white pages list **the other** adopted standards for the structural, mechanical, and electrical sections. Additionally, the references to plumbing standards found in the white pages should be deleted.

BCD will publish an errata containing editorial changes. ■

Board meeting dates

Sun	Mon
1	2
8	9

Electrical & Elevator Board

Meets at 9:30 a.m. on the fourth Thursday of each month:

- May 25
- June 22

Building Codes Structures Board

Meets at 9:00 a.m. on the first Wednesday of each month:

- June 7

Manufactured Structures & Parks Advisory Board

Meets at 9:30 a.m. on the second Thursday of each quarter:

- July 13

State Plumbing Board

Meets at 9:00 a.m. on the third Friday of every other month:

- June 16

Board of Boiler Rules

Meets at 9:30 a.m. on the first Tuesday of each quarter:

- June 6

Tri-County Building Industry Service Board

Meets at 9:30 a.m. on the second Wednesday of each month:

- May 10 (City of Wilsonville)
- June 14 (City of Wilsonville)

MEETINGS ARE HELD IN THE SALEM BCD
CONFERENCE ROOM AT
1535 EDGEWATER ST. NW
EXCEPT THE TRI-COUNTY BOARD



Subscription and address corrections

- Address correction — Send to:
BUILDING CODES DIVISION
PO BOX 14470
SALEM, OR 97309-0404

- New subscription — Enclosed is my check payable to DCBS for \$25 for the calendar year 2000 (Jan.-Dec.) subscription.

Send to:

DEPARTMENT OF CONSUMER
& BUSINESS SERVICES
FISCAL SECTION
350 WINTER ST. NE
SALEM, OR 97301-3878

Name: _____

Title/Company: _____

Address: _____

City/State/ZIP: _____

Phone: (_____) _____

DEPARTMENT USE ONLY 1087/70050

Stakeholder meetings scheduled

Sun	Mon
1	2
8	9

Stakeholder meetings are open-forum meetings to discuss questions or concerns related to building codes programs. Joe Brewer, administrator, and Etta Foote, field operations manager, will discuss your questions or concerns about the programs serviced by the state, May 23, 6:00 p.m., in Lakeview. The meeting address will be decided later; please see the BCD Web site for updates.

Grant and Wasco county meeting dates are the next to be announced. ■

440-2666 (5/00COM)



**DEPARTMENT OF
CONSUMER
& BUSINESS
SERVICES**
Building Codes Division
1535 Edgewater St. NW
PO Box 14470
Salem, OR 97309-0404

CODE LINK

STATE OF OREGON • BUILDING CODES DIVISION

CodeLink is a bimonthly publication of the Oregon Department of Consumer & Business Services Building Codes Division.

Editor

Louann Rahmig

Design & Layout

DCBS Communications

BCD Administrator

Joseph A. Brewer III



In compliance with the *Americans with Disabilities Act (ADA)*, this publication is available in alternative formats. Call the editor, (503) 373-7438.

Information in *CodeLink* may be republished without permission.

Visit our Internet Web site:
www.cbs.state.or.us/bcd

Bulk Rate
U.S. Postage
PAID
Salem, OR
Permit No. 24